

Colorfeed CF 380



Neckpiece for one or two CF 380 with integrated alibration gate



Easy to open when cleaning or changing dosing screw



The hoppers are easily mounted and changed



Neckpiece for 4 pcs CF 380 or CF-500



Rational Materials Handling for the Plastic and Process Industry

Colorfeed CF 380



An open, modern construction that makes the unit nice to operate. A hinged motor part simplifies the changing of dosing screw and makes the dosing unit easy to clean when changing materials.

Fits most of the ICEVA Hopper Loaders, which are easy to mount afterwards. Automation after demand.

Compact format, easy to install and move. Fits with standard parts on most machines.

Gives a very accurate dosing and an even and high process reliability.

Dosing screws and sleeves are compatible with earlier models of Colorfeed (CF-210, 310 and 410). Available with or without hinged end on the screw.

Rigid and compact aluminium housing with stainless steel hoppers in several sizes, 3, 6 och 10 liter (compatible with the older versions).

Two different motor alternatives to reach the right capacity range.

A modular built unit makes CF-380 very flexible and ensures a wide range of use. A vast collection of accesories enables CF-380 to suit most applications.



Capacity guide for choice of screw set and motor.

(Material: HDPE, Ø 3 mm, density 0,956 g/cm³)

Screw/sleeve (mm)	Motor power (W)	Capacity range (Kg/h)
5 / 12	12	0,02 - 0,70
8 / 14	12	0,05 - 1,75
8 / 16	12	0,08 - 2,70
8 / 18	12	0,17 - 4,20
12 / 18	12	0,17 - 4,70
12 / 18	24	0,36 - 13,0
12 / 20	24	0,50 - 20,0
16 / 26	24	1,0 - 30,0

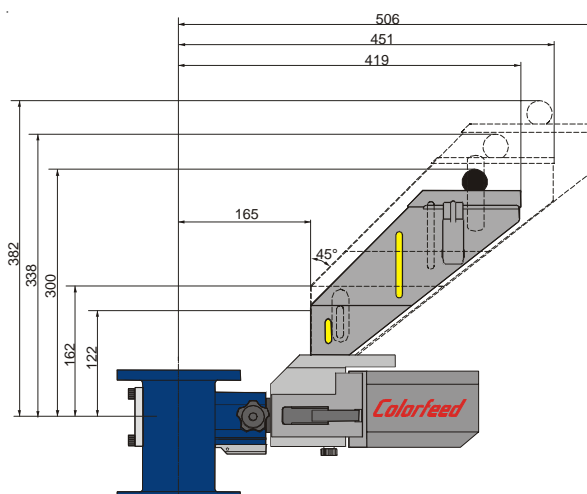

2005/03 Subject to alteration



Plastgatan 15
SE-261 71 Landskrona, Sweden
Tel +46 (0)418 44 90 50
Fax +46 (0)418 43 54 99
info@iceva.se www.iceva.se