

Colorfeed CF 500 & 600

The dosing unit for heavy duty applications.

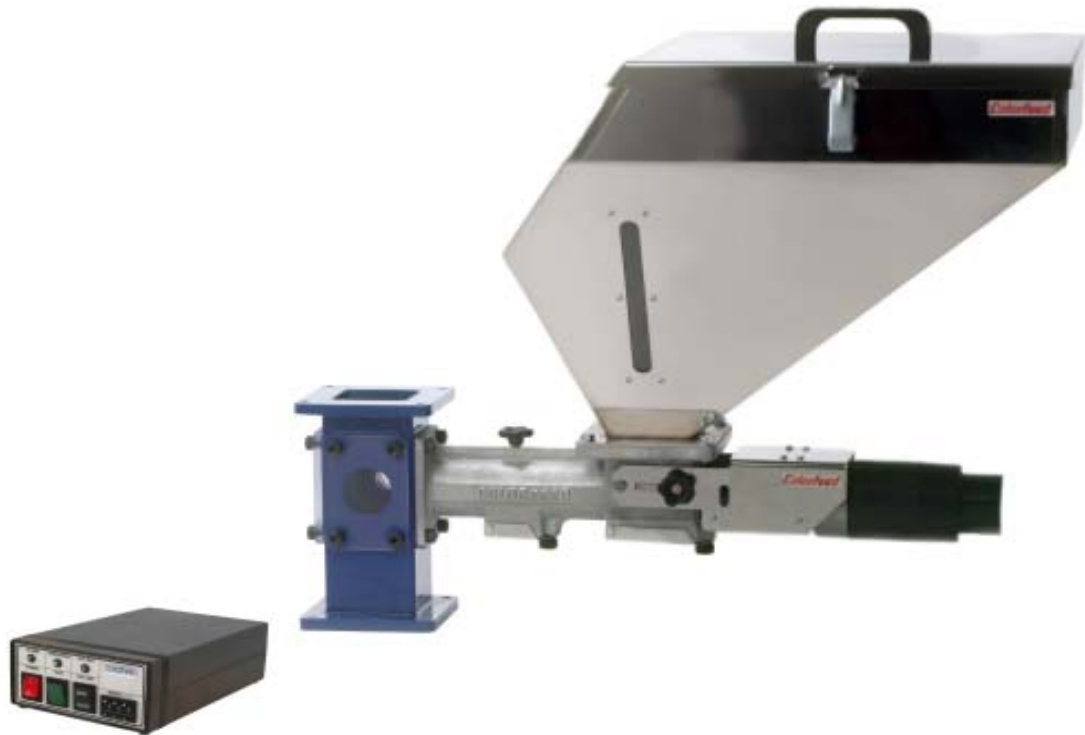

**Neckpiece for
4 pcs CF 380 or CF-500**



**Easy to open when cleaning
or changing dosing screw**



Rational Materials Handling for the Plastic and Process Industry

Colorfeed CF 500 & 600



An open, modern construction that makes the unit nice to operate.



A hinged motor part simplifies the changing of dosing screw and makes the dosing unit easy to clean when changing materials.



Fits most of the ICEVA Hopper Loaders, which are easy to mount afterwards. Further automation after demand.



Compact format, easy to install and move. Fits with standard parts on most machines.



Gives a very accurate dosing and an even and high process reliability.



Rigid and compact aluminium housing with stainless steel hoppers in several sizes, 20 or 50liter

Two different gearboxes to reach the right capacity range.



A modular built unit makes CF-500 / 600 very flexible and ensures a wide range of use.

A vast collection of accessories enables dosing unit to suit most applications.

Capacity guide line

Screw/sleeve Motor power Capacity range

Model.	Screw	sleeve	kg/h
CF-500	8	15	0,14-7,4
	13	20	0,14-17
	17	25	0,7-45
	25	34	2,15-148
	-	38	8-470
CF-600	-	38	13-840

Material: HDPE, Ø 3 mm, density 0,956 kg/dm³

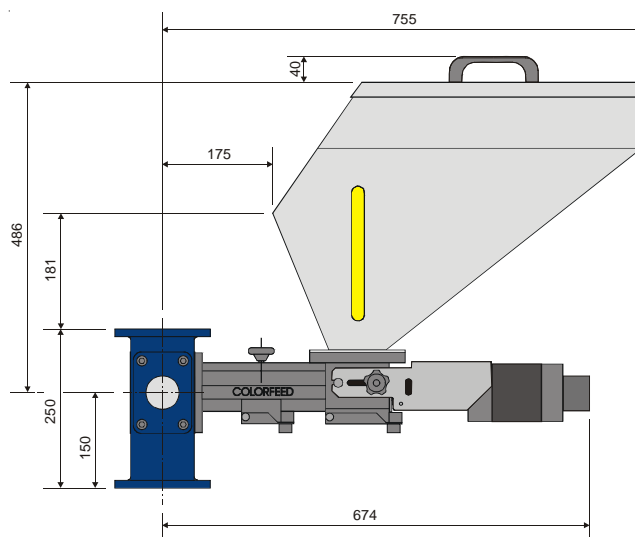

2005/09 Subject to alteration



Plastgatan 15
SE-261 71 Landskrona, Sweden
Tel +46 (0)418 4490 50
Fax +46 (0)418 4354 99
info@iceva.se www.iceva.se